

PR-5-V Vapor Wagon

The "Ply-Rite" Torch Wagon System is an all-in-one modified bitumen application system. Using six powerful burner heads and a squeeze trigger control, the Ply-Rite Wagon is easy to use. Simply drop the roll in-between the support arms, and begin to put down a roof. Consult a Burners, Inc. customer service representative for complete kit options.

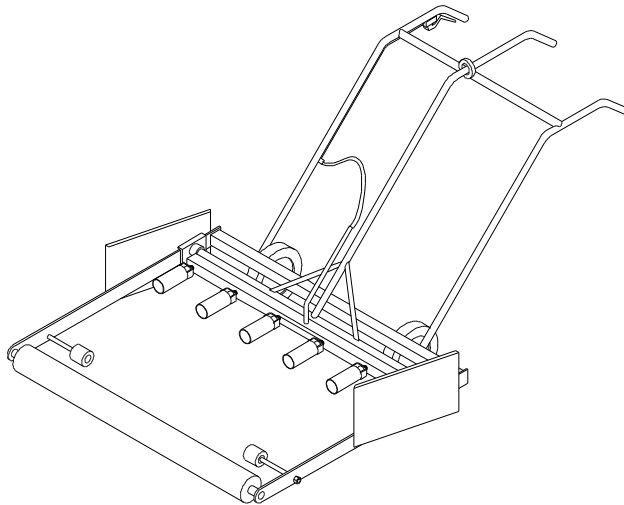

Specifications

BTU Rating	750,000 @ 25psi
Fuel	Vapor L.P.Gas (propane)
Fuel Connection	9/16"-18 LH (ball seat)
Burner Heads	6
Width	42-1/2"
Length	72"
Height	36"
Wheel Base	24-1/2"
Weight	175 lbs
Color	Blue

- Fully welded construction
- Adjustable burner pitch & distance
- Every unit is function tested
- Shipped with HD squeeze valve
- Includes adjustable pilot setting
- Ready to go
- Easy to use

GUARANTEE

ALL EQUIPMENT IS GUARANTEED TO BE FREE FROM DEFECT IN EITHER MATERIAL OR WORKMANSHIP. ALL EQUIPMENT IS GUARANTEED TO THE EXTENT OF OPERATING SPECIFICATIONS OF THE EQUIPMENT. NO CLAIM WILL BE ALLOWED FOR SUBSEQUENT DAMAGE CAUSED BY IMPROPER INSTALLATION, IMPROPER USE (MISUSE), NEGLIGENCE, OR IMPROPER FUEL AND/OR ELECTRICAL SUPPLY (IF APPLICABLE).

While this information is presented in good faith and believed to be accurate - Burners, Inc. does not guarantee satisfactory results from reliance upon such information. Nothing contained within this document is to be construed as a warranty or guarantee, expressed or implied, regarding the performance, merchantability, fitness or any other matter with respect to this product, nor as a recommendation to use this product in a specific application. Burners, Inc. reserves the right, without notice, to alter, or improve the designs or specifications of this product, described herein. Rev.: April, 2003