

P.A.T. Propane-Air Torch

The P.A.T. Torch is specifically designed for road surface crack and repair preparation. Combined with your air compressor and propane source, this torch assembly will generate an extremely high heat output along with a high speed blast of air, to clean & dry road surface cracks.

NOTE - The P.A.T. Torch Kit comes complete with torch, propane hose, propane pressure regulator, and flint striker. (air hose, air compressor & propane tank are not included).

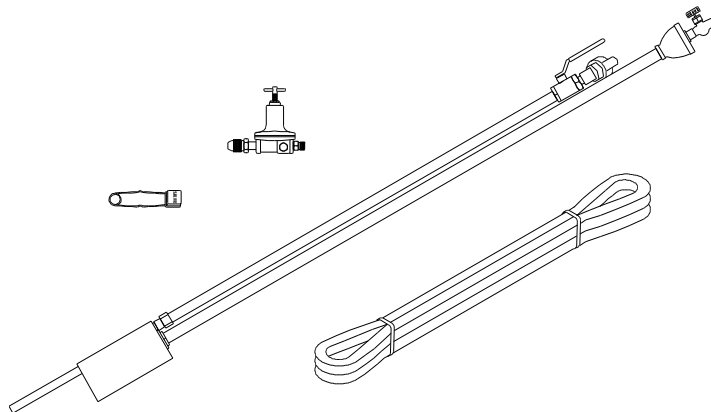

Specifications	
BTU Rating	300,000 @ 55psi
Temperature Output	2000°F - 2400°F
Fuel	Vapor L.P.Gas (propane)
Fuel Connection	9/16"-18 LH (ball seat)
Air Consumption	100 - 175 cfm
Air Connection	1/2" Twist-Lock (Chicago)
Length	58"
Diameter - Torch	2-7/8"
Diameter - Air Nozzle	5/8"
Weight - Torch	7 lbs
Color	Brushed Aluminum

- **Cleans & dries with high temperature**
- **Lightweight aluminum body**
- **Heavy duty, stainless steel air injector**
- **Extended work seasons**
- **Finger tip control for air & fuel**
- **Includes propane hose & regulator**

GUARANTEE

ALL EQUIPMENT IS GUARANTEED TO BE FREE FROM DEFECT IN EITHER MATERIAL OR WORKMANSHIP. ALL EQUIPMENT IS GUARANTEED TO THE EXTENT OF OPERATING SPECIFICATIONS OF THE EQUIPMENT. NO CLAIM WILL BE ALLOWED FOR SUBSEQUENT DAMAGE CAUSED BY IMPROPER INSTALLATION, IMPROPER USE (MISUSE), NEGLIGENCE, OR IMPROPER FUEL AND/OR ELECTRICAL SUPPLY (IF APPLICABLE).

While this information is presented in good faith and believed to be accurate - Burners, Inc. does not guarantee satisfactory results from reliance upon such information. Nothing contained within this document is to be construed as a warranty or guarantee, expressed or implied, regarding the performance, merchantability, fitness or any other matter with respect to this product, nor as a recommendation to use this product in a specific application. Burners, Inc. reserves the right, without notice, to alter, or improve the designs or specifications of this product, described herein. Rev.: April, 2003