

## NG-300 Vapor Burner

Our NG series, vapor power burners are used for general purpose heating applications where unattended use and full flame monitoring is required. This system comes complete with a full automatic ignition and flame monitoring control system installed. The NG series can be used with most low pressure vapor fuels. Please contact your Burners, Inc. Sales Representative for details.

*IMPORTANT* - Consult your local municipal governing agency for appropriate installation building codes.

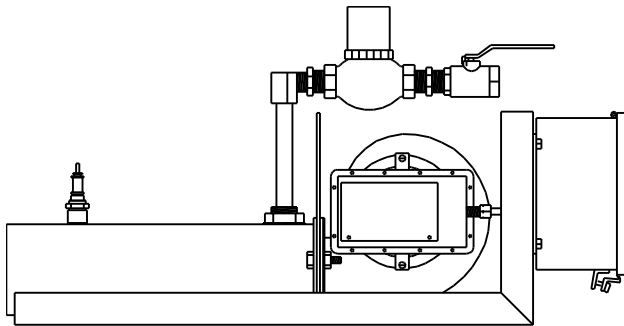

### Specifications

BTU Rating	300,000 @ 8" W.C.
Fuel	Vapor gas fuel - specify
Fuel Connection	1/2" npt
Sleeve—Diameter	3-1/2"
Sleeve—Material	T-304 Stainless Steel
Length	24"
Height	14-1/2"
Base	10-1/4" x 20-1/4"
Weight	35 lbs
Power Requirement	115 VAC - 5 amp - 60Hz

- **Fully assembled construction**
- **Every unit is function tested**
- **Shipped with HD brass valve**
- **On-board combustion blower**
- **Include adjustable air shutters**
- **Easy installation**

### GUARANTEE

ALL EQUIPMENT IS GUARANTEED TO BE FREE FROM DEFECT IN EITHER MATERIAL OR WORKMANSHIP. ALL EQUIPMENT IS GUARANTEED TO THE EXTENT OF OPERATING SPECIFICATIONS OF THE EQUIPMENT. NO CLAIM WILL BE ALLOWED FOR SUBSEQUENT DAMAGE CAUSED BY IMPROPER INSTALLATION, IMPROPER USE (MISUSE), NEGLIGENCE, OR IMPROPER FUEL AND/OR ELECTRICAL SUPPLY (IF APPLICABLE).

While this information is presented in good faith and believed to be accurate - Burners, Inc. does not guarantee satisfactory results from reliance upon such information. Nothing contained within this document is to be construed as a warranty or guarantee, expressed or implied, regarding the performance, merchantability, fitness or any other matter with respect to this product, nor as a recommendation to use this product in a specific application. Burners, Inc. reserves the right, without notice, to alter, or improve the designs or specifications of this product, described herein. Rev.: April, 2003