

## 312 Cylinder Collar

The Burners, Inc. protective cylinder collar cap is designed for use on 100# (23.5 gal) propane tanks and allows the collar cap to remain in place during the use of the tank. The open frame design easily allows users to attach fittings and access the cylinder valve. Sturdy 12ga, fully welded construction.

**IMPORTANT** - This protective cylinder collar cap is only intended to be used for valve protection during transportation. It is not designed to be used as a lifting device for the cylinder..

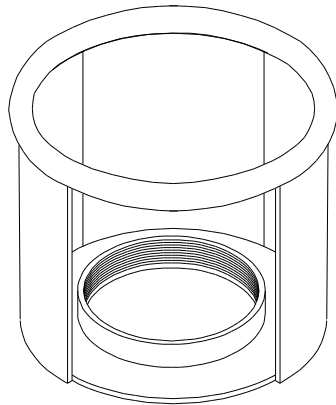

<b>Specifications</b>	
Material	12ga Mild Steel Plate
Thread	3-1/2"-11 tpi
Width	6-1/2"
Height	5-1/2"
Base	6" diameter
Weight	3.25 lbs
Color	Machine Grey

- Fully welded construction
- Baked enamel finish
- Easy installation

### **GUARANTEE**

ALL EQUIPMENT IS GUARANTEED TO BE FREE FROM DEFECT IN EITHER MATERIAL OR WORKMANSHIP. ALL EQUIPMENT IS GUARANTEED TO THE EXTENT OF OPERATING SPECIFICATIONS OF THE EQUIPMENT. NO CLAIM WILL BE ALLOWED FOR SUBSEQUENT DAMAGE CAUSED BY IMPROPER INSTALLATION, IMPROPER USE (MISUSE), NEGLIGENCE, OR IMPROPER FUEL AND/OR ELECTRICAL SUPPLY (IF APPLICABLE).

While this information is presented in good faith and believed to be accurate - Burners, Inc. does not guarantee satisfactory results from reliance upon such information. Nothing contained within this document is to be construed as a warranty or guarantee, expressed or implied, regarding the performance, merchantability, fitness or any other matter with respect to this product, nor as a recommendation to use this product in a specific application. Burners, Inc. reserves the right, without notice, to alter, or improve the designs or specifications of this product, described herein.