

## SAFETY CHECKLIST

- Always use protective gloves, long sleeve shirt, long pants, boots and OSHA approved protective eyewear.
- Always use the torch in a safe area, free from all combustibles and flammable liquids & vapors.
- Always have a ABC type fire extinguisher within 25ft of your work area.
- Always keep the propane gas supply cylinder in an upright position. NEVER LAY THE PROPANE CYLINDER DOWN!
- Never operate the torch when a gas leak is present, or gas odor is detected.

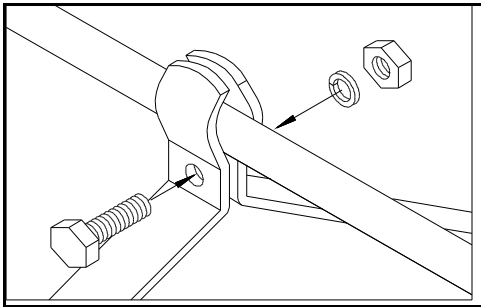

### OPTIONAL TORCH STAND BRACKET ASSEMBLY

- 1) Align the two (2) pieces of the torch stand bracket assembly around the torch gas tube, near the burner head.
- 2) Using a 7/16" wrench set, tighten the supplied nut & bolt assembly to securely hold the torch stand to the torch.

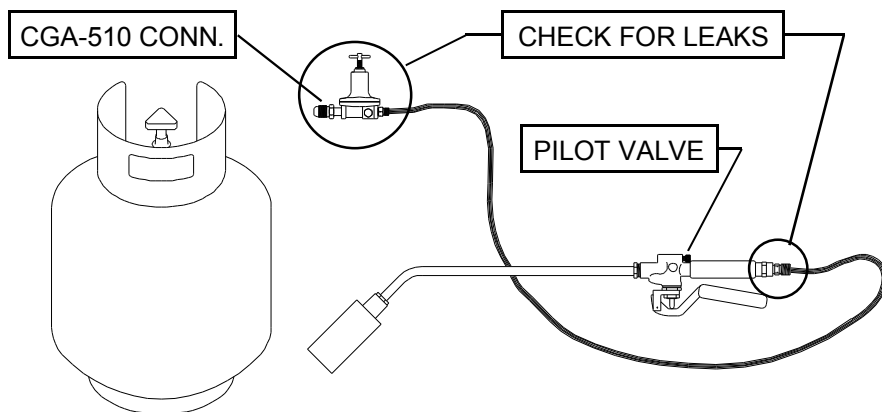

Burners, Incorporated  
Milford, Michigan  
(248) 676-9141  
<http://www.burnersinc.com>

# Vapor Propane Hand Torch

For Models:  
FV-1, FV-15, FV-16 & FV-17 Torch Kits

## Instruction Booklet

**\* \* I M P O R T A N T \* \***  
**\* \* READ THIS FIRST \* \***

**Read this manual before you use  
this torch or attempting to light**

**Keep this booklet in a safe place  
for future reference.**

# burners, inc.

## Vapor Propane Torch

FV-1, FV-15-, FV-16 & FV-17

**IMPORTANT - Please read all instructions before attempting to operate this torch. Failure to follow all instructions may result in bodily injury.**

### FOR YOUR SAFETY

If you smell gas:

- Shut off all gas supplies.
- Extinguish all open flames.
- Contact a qualified gas service technician for assistance.

**This torch will produce extremely hot flames, and will cause severe burns to exposed skin.**

**You must always use hand and eye protection when using this torch. It is recommended that you use OSHA approved eye protection and leather gloves whenever using this torch.**

**DO NOT use this torch in any area containing flammable vapors such as gasoline, paint thinner, or degreaser.**

**DO NOT use this torch near flammable material such as dead & dry weeds, pine needles, sawdust, & paper.**

This torch is only intended for outdoor use only.

This torch is designed for use with a vapor withdrawal LPG (propane type CGA-510) cylinder only.

Only allow properly trained adults to operate this torch.

Do not allow children to operate this torch.

### SET-UP INSTRUCTIONS

#### ***Before you begin ...***

Inspect all material for damage. Make sure all brass connectors are free from breaks or damage. Make sure torch assembly is not bent or broken.

**DO NOT USE THIS TORCH IF ANY PART IS DAMAGED OR BROKEN.**

Connect the supplied hose to both the pressure regulator and the torch (refer to back cover illustration). Both end of the hose have left-handed, swivel nuts that DO NOT require any pipe sealant. You will need both a 5/8" & 11/16" open-end wrench to securely fasten these fittings.

You must provide a LPG vapor withdrawal propane supply cylinder. This cylinder must be approved by the US Department of Transportation for propane service.

Inspect the O-ring (if applicable) on the CGA-510 cylinder connector fitting, on the propane pressure regulator, for damage. If damaged, do not use the torch. Replace the O-ring.

Connect the CGA-510 cylinder connector fitting to LPG vapor withdrawal propane supply cylinder. (refer to back cover illustration). DO NOT OVER TIGHTEN.

Make sure the pilot control valve is turned completely OFF (fully clockwise).

**SLOWLY** open the gas valve on the propane supply cylinder. Immedi-

ately check for any gas leaks on the torch control valve, the gas hose, the LPG (propane) pressure regulator, and the CGA-510 tank connector fitting using a soapy water or suitable gas leak detection solution (available at your local LP Gas Retailer).

**DO NOT USE A MATCH OR ANY OTHER OPEN FLAME TO DETECT FOR GAS LEAKS.**

**DO NOT ATTEMPT TO LIGHT OR OPERATE THIS TORCH IF THERE IS ANY EVIDENCE OF A GAS LEAK, OR YOU SMELL GAS.**

If a leak is discovered, immediately turn OFF the gas valve on the propane supply cylinder.

### LIGHTING INSTRUCTIONS

#### ***Before you begin ...***

Make sure you have followed the SET-UP INSTRUCTIONS completely.

**SLOWLY** open the gas valve on the propane supply cylinder and turn the adjusting handle on the pressure regulator completely **CLOCKWISE**. Check all connections on the torch, hose and cylinder for leaks, using a soapy water solution or a suitable gas leak detection solution (available from your local LP gas supplier). Watch all connections carefully. If bubbles appear, a leak is present in that area. Shut OFF the gas supply valve on the propane supply cylinder. **DO NOT OPERATE, OR ATTEMPT TO LIGHT THE TORCH WHEN A LEAK IS PRESENT.**

Open the pilot control valve on the torch 1/8 turn, or until a small amount of gas begins to escape from the torch. Using the flint striker supplied with this kit, ignite the gas at the burner head end of the torch.

**NEVER USE A MATCH OR CIGARETTE LIGHTER TO IGNITE THE GAS.** This can lead to serious burns and injury.

**DO NOT ATTEMPT TO IGNITE THE GAS FOR MORE THAN FIVE (5) SECONDS.** If you can not light the torch within 5 seconds, turn OFF both the gas control valve on the torch and the gas supply valve on the propane supply cylinder.

Adjust the size of the pilot flame by using the adjusting knob, on the LPG (propane) pressure regulator, or pilot control valve on the torch.

### PERFORMANCE NOTE

The CGA-510 cylinder connector may be equipped with a safety device known as an **Excess-Flow Safety Check**. This safety device prevents large amounts of propane from escaping if there is a hose failure. **This safety device may activate when you first turn ON the propane gas supply.** To correct this problem, simply close the propane gas supply valve on the propane cylinder, wait 15 seconds, and then very slowly open the propane supply valve. This should return the torch system to a normal performance level.

If your torch is still not performing at a normal level, have your local propane supplier verify that your propane supply cylinder is operating correctly.

### SHUT-OFF INSTRUCTIONS

Turn OFF the valve on the gas supply cylinder first. Allow all of the gas to burn completely and the flame to extinguish at the burner head.

Turn OFF the gas control valve on the torch.