

CYLINDER PALLETES

When cylinder lifting and transporting is needed, our cylinder pallets keep things safe. Safety yellow color, locking pins on gates, and heavy gauge lifting platform are all standard features of our CP-series cylinder pallets. The paint is baked on, for a long lasting finish. Our racks are built of **100% welded construction**. They come **fully assembled**, saving you costly set-up time and eliminates the chance of loose bolts.

Forklift Rails
Fully Assembled
Baked Safety Yellow

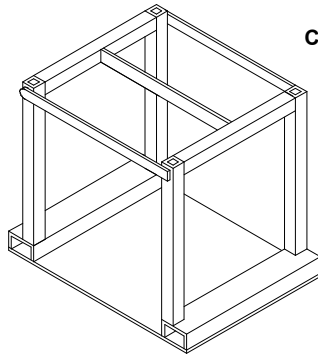

CP-4-100

Cylinder Pallet - 100# Propane Cylinders

Used for 100# LPG (propane) cylinders, these heavy-duty cylinder pallets can be used for lifting, moving and transporting. All steel construction, lock pin gates, and warning signs make the CP-100 series the perfect choice handling 100# LPG cylinders.

M/N	CAPACITY	HGTH	WDTH	DEPTH	WGT
CP-4-100	4 - 100# Tanks	40"	49"	33"	245#
CP-6-100	6 - 100# Tanks	40"	49"	49"	340#

Forklift Rails
Fully Assembled
Baked Safety Yellow

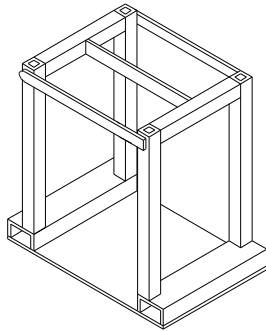

CP-4

Cylinder Pallet - Welding Cylinders

Designed for high-pressure welding gas cylinders, these cylinder pallets will accommodate almost all 9"-10" diameter cylinders that are at least 50" tall. All steel construction, lock pin gates, and warning signs make the CP series the perfect choice handling 50# high pressure cylinders.

M/N	CAPACITY	HGTH	WDTH	DEPTH	WGT
CP-4	4 - 50# Tanks	40"	37"	26"	175#
CP-6	6 - 50# Tanks	40"	37"	38"	240#
CP-8	8 - 50# Tanks	40"	37"	49"	300#

CUSTOM FABRICATION SERVICE IS NOW AVAILABLE

Proto-type Development / Small -to- Medium Production Runs

Let Burners, Inc. custom fabrication department help you on your next project. Our in-house machining and custom build departments are ready to work with your design team to bring your concepts into reality.

CUTTING

Precision Band Saws
Hydraulic Shears
Light gauge Sheet metal Shear
Automated Plasma Torch

FORMING

Hydraulic Breaks
Sheet metal Pan Breaks
Slip rollers (minimum diameter 1")
Tubing Benders
Tubing/Pipe Coilers

MACHINING

Bridgeport Mills
Lathes
Automated Threading
Pipe Threaders
Drill Presses

FABRICATION

Welder, TIG
Welder, MIG (Mild & Stainless)
Bench Grinders & Belt Sanders
Finishing & Polishing Tables

TESTING

Magna-Flux Weld Inspection
Strain Gauge

FINISHING

Parts Cleaning
Pressure Washer Tanks
Paint Booth
Baking Oven

SHIPPING

Individual Part Boxing, Palletizing & Banding

Call us at (800) 878-2876, or visit our fabrication website at <http://www.fab.burnersinc.com>