

Vapor Propane Burner—Cast Iron—Vertical Fire

Our cast iron, vapor propane burners are designed to provide dependable, high volumes of heat. Originally designed for portable and commercial cooking, these burners have also been used in a wide variety of other applications, including fish cookers, popcorn kettles, asphalt heating systems, industrial welding preheat tables, barbecues & smokers. These burners are perfect for round, adjustable flame patterns.

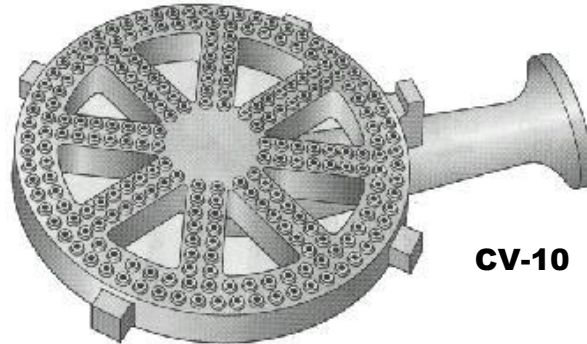
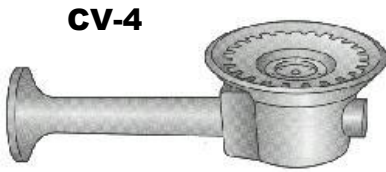

M/N	BTU RATING	PRES.	DIA.	LGTH	HGHT	WEIGHT
CV-4	13,000 btu/h	4" - 14" WC	4-1/4"	12"	3-1/4"	5 lbs.
CV-4-H	150,000 btu/h	25 psi	4-1/4"	12"	3-1/4"	5 lbs.
CV-6	13,000 btu/h	4" - 14" WC	6"	9-1/2"	2-3/4"	5 lbs.
CV-10	70,000 btu/h	4" - 14" WC	10"	15"	6"	20 lbs.

IMPORTANT NOTE - All CV series burners must be ordered with an appropriate orifice spud, or valve/orifice assembly for proper operation.

Vapor Propane Burners—Sleeve Style—Straight Fire

Our FV series, vapor burners are used for general purpose heating applications where the system is constantly monitored for proper operation. With solid bases, permanently mounted, these burners are built solid and are economically priced.

These burners are also available in stainless steel (add a -SS to the part number).

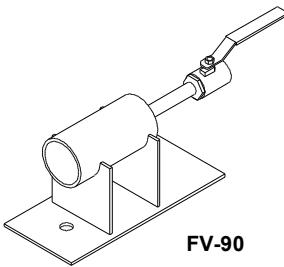

M/N	BTU RATING	PRES.	DIA.	LGTH	HEIGHT	WEIGHT
FV-90	100,000 btu/h	25 psi	2"	11"	4-1/2"	3 lbs.
FV-40	200,000 btu/h	25 psi	2-3/4"	12"	5-1/4"	4 lbs.
FV-60	300,000 btu/h	25 psi	3-1/2"	12"	5-7/8"	4 lbs.
FV-70	500,000 btu/h	25 psi	4-1/2"	15"	9-3/8"	9 lbs.

Vapor Propane Burners—Sleeve Style—With 100% Safety

This series of burners are the same as the above burners and include a 100% gas shut-off valve (thermocouple response) to monitor the flame and shut down if the thermocouple is cooled down (due to the loss of flame).

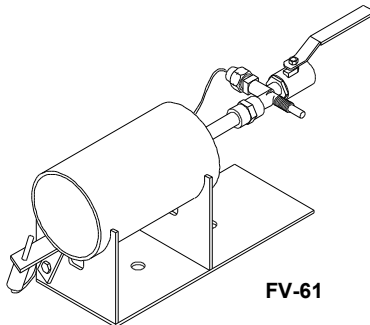

M/N	BTU RATING	PRES.	DIA.	LGTH	HEIGHT	WEIGHT
FV-91	100,000 btu/h	25 psi	2"	13-1/2"	4-1/2"	4 lbs.
FV-41	200,000 btu/h	25 psi	2-3/4"	14-1/2"	5-1/4"	5 lbs.
FV-61	300,000 btu/h	25 psi	3-1/2"	14-1/2"	5-7/8"	5 lbs.
FV-71	500,000 btu/h	25 psi	4-1/2"	17-1/2"	9-3/8"	10 lbs.

Vapor Propane Utility Torch/Burner

The FV-12-K Torch / Burner Kit is ideal for boiling and cooking large quantities of water & food. With less than 9" of vertical height, the FV-12 is designed to slide under most outdoor cooking equipment.

Our remote valve keeps your hands away from the heat when adjusting the flame height or intensity.

The FV-12-K can be used with or without a pressure regulator.

Complete with Torch/Burner, 10feet of hose, a LP Gas (propane tank connector) and a flint striker.

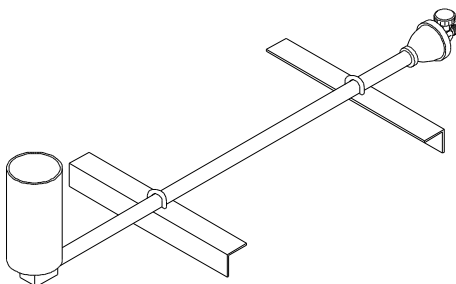

M/N	BTU RATING	PRES.	DIA.	LGTH	HEIGHT	WEIGHT
FV-12-K	500,000 btu/h	Tank	3"	41"	9"	10 lbs.