

Light Weight Aluminum Body
Stainless Steel Air Injector
Adjustable Gas & Air
Simple Operation

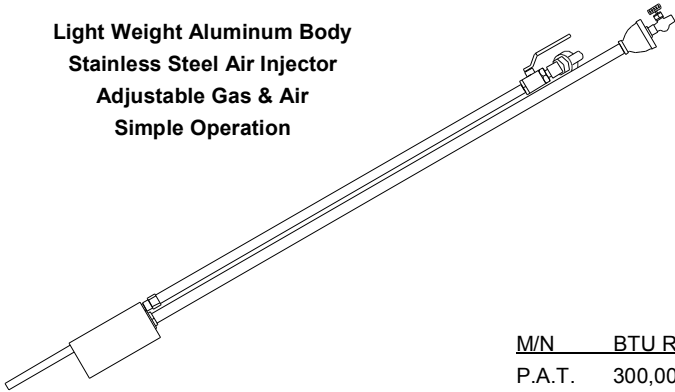

Crack Sealing - Paving Torch

P.A. Torch

Combined with your air compressor and propane tank, this powerhouse generates a high intensity flame output, along with a high temperature heat blast to clean and dry any crack in the paved work area.

Complete with:

- P.A. torch assembly
- Adjustable propane gas regulator
- 50 feet of propane gas hose
- Striker & instruction manual

M/N	BTU RATING	GAS PRES.	DIA.	LGTH	AIR CONN.	TORCH WT.
P.A.T.	300,000 btu/h	55 psi	2-7/8"	58"	1/4 turn Twist-Loc	7.0 lbs.

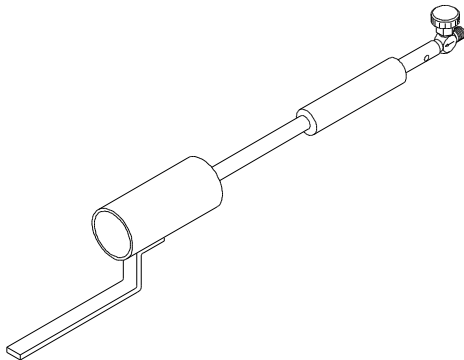

Patcher Kettle Torch & Burner

This torch was designed for use in small, portable patching and asphalt kettles. The steel torch head "Z" bracket is used to support the FV-11-S Torch as it is aimed into a firing chamber. The torch can also be easily removed and used to spot heat your work area.

Complete with:

- FV-11-S torch assembly
- Adjustable propane gas regulator
- 10 feet of propane gas hose
- Striker & instruction manual

M/N	BTU RATING	PRES.	DIA.	LGTH	TORCH WT.
FV-11-S-K	150,000 btu/h	30 psi	2-3/8"	25"	4.0 lbs.

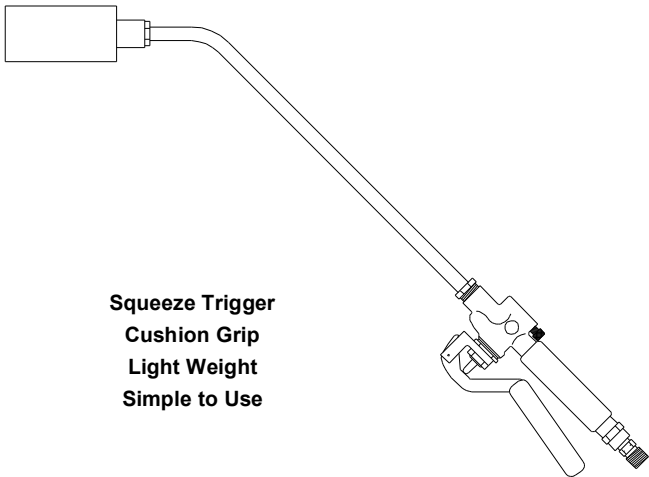

Squeeze Trigger
Cushion Grip
Light Weight
Simple to Use

Squeeze Trigger Hand Torch - Standard

Primarily designed for the roofing & paving industries, the FV-15 hand torch is built tough and easy to use. With an adjustable standing pilot flame, the FV-15 torch is always ready to go, just squeeze the trigger, and a full force flame is released towards your work area.

The FV-15 torch has been used for other applications as well, like shrink wrapping, industrial processing, floor & road drying.

Complete with:

- FV-15 torch assembly
- Adjustable propane gas regulator
- 25 feet of propane gas hose
- Striker, stand & instruction manual

M/N	BTU RATING	PRES.	DIA.	LGTH	TORCH WT.
FV-15-K	520,000 btu/h	55 psi	2"	32"	2.4 lbs.

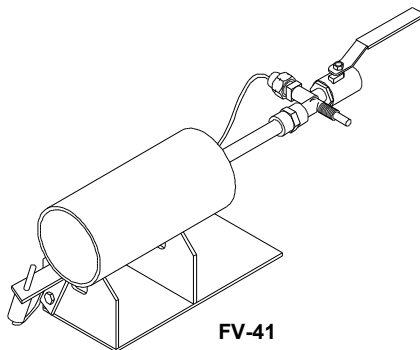

FV-41

Vapor Propane Burners—Sleeve Style—With 100% Safety

Our FV series, vapor burners are used for general purpose heating applications where the system is constantly monitored for proper operation. and includes a 100% gas shut-off valve (thermocouple response) to monitor the flame heat and shut down if the thermocouple is cooled down (due to the loss of flame).

These burners are perfect replacements for melters and patchers

M/N	BTU RATING	PRES.	DIA.	LGTH	HEIGHT	WEIGHT
FV-91	100,000 btu/h	25 psi	2"	13-1/2"	4-1/2"	4 lbs.
FV-41	200,000 btu/h	25 psi	2-3/4"	14-1/2"	5-1/4"	5 lbs.
FV-61	300,000 btu/h	25 psi	3-1/2"	14-1/2"	5-7/8"	5 lbs.
FV-71	500,000 btu/h	25 psi	4-1/2"	17-1/2"	9-3/8"	10 lbs.