

Hot Air "Ply-Rite" Handheld Heater Applicator & Roof Dryer

With the *Hot Air Ply-Rite* Flameless Roofing Application System, you can now take your roofing project to the next level in performance and safety.

Flameless Modified Bitumen Installation and Roof Drying.

- 1,200°F Hot Air
- 100 mph Air Flow
- Automatic Ignition
- Constant Flame Monitor
- Stainless Steel Heater Tube & Nozzle

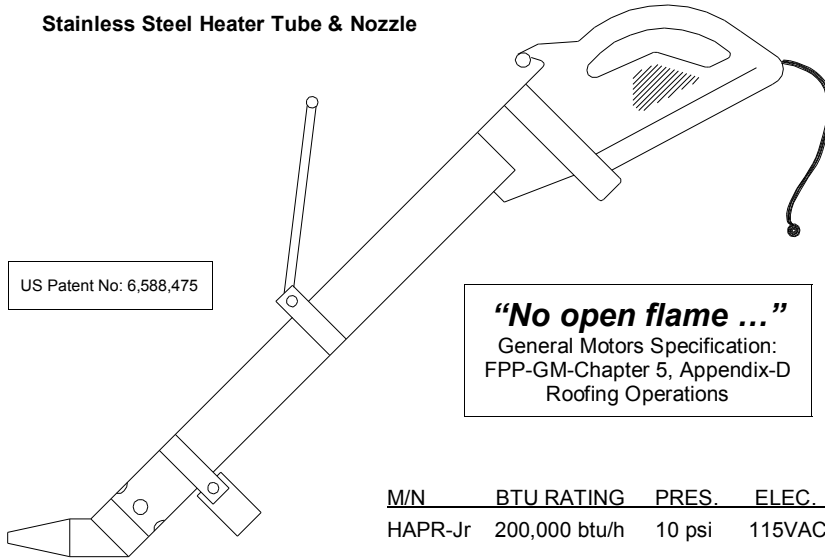

Complete with:

- Hand-held, hot air roofing heater assembly
- Propane gas regulator
- 25 feet of propane gas hose
- Adjustable handle, stand & instruction manual

Using the energy of LP Gas, and the convenience of standard 115VAC electricity, the *Hot Air Ply-Rite Jr.* generates a large amount of hot air that can be directed at the roof deck.

Simply turn *ON* the switch and the start-up process begins automatically and runs while under constant monitoring by the on-board safety management controller.

One Tool - Many Uses - Simple to Use

Hot Air Ply-Rite ...

M/N	BTU RATING	PRES.	ELEC.	DISCHARGE.	LGTH	HGTH	WDTH	TORCH WT.
HAPR-Jr	200,000 btu/h	10 psi	115VAC	1/2" x 12"	52"	12"	8"	13 lbs.

Coming Soon ...
No open flame Wagon and Mini
Applicator & Dryer

Propane Roofing Wagon Modified Bitumen Applicator & Roof Dryer

Just one look at the Burners, Inc. Roofing Wagon, and you'll recognize the quality. Made from structural iron, this wagon is built to last. We offer the Roofing Wagon in both a standard vapor model (PR-7-V) and a liquid version (PR-7-L) for use in colder weather. When ordering, please ask a sales consultant which model is right for you. The PR-7 series wagons all come with the 6-head torch wagon, 50 feet of hose, an adjustable pressure regulator and operating instructions.

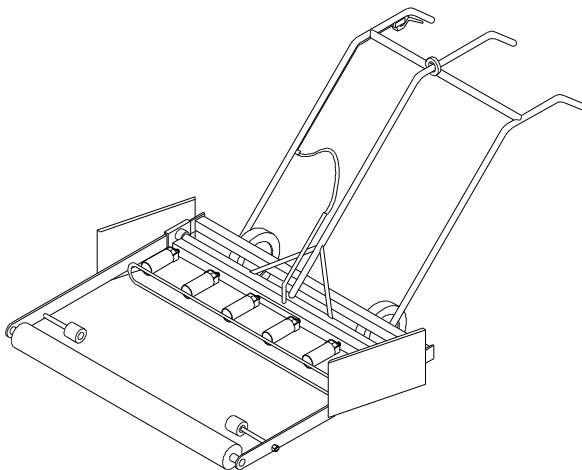

FEATURES:

- 6 high output, wind resistant burner heads
- 35# weighted roller bar - for even pressure on the roll
- Adjustable burner head angle pitch
- Adjustable burner to roll distance
- Squeeze Trigger - Instant On - and adjustable standing pilot
- Intermediate boogie wheels to guide roll during installation

Six Burner Heads - Heavy-Duty Design - Built to Last

M/N	BTU RATING	PRES.	FUEL	LGTH	WDTH	HGT	WGHT.
PR-7-L	800,000 btu/h	25 psi	Liquid	70"	43"	38"	185 lbs.
(Uses Liquid Propane - Great for cold weather use.)							
PR-7-V	800,000 btu/h	25 psi	Vapor	70"	43"	38"	183 lbs.
(Uses Vapor Propane - The same tanks as your torches.)							