

Liquid Propane Utility Torches - Standard

Liquid propane torches are used when quick spot heating is required. Our short handle style allows the operator mobility and portability. Liquid propane torches work great at any temperature and won't cause the tank to freeze up.

With the ability to operate on a wide variety of pressures, these torches are designed for steady operation - regardless of fuel level or ambient temperatures.

A gas pressure regulator & hydrostatic relief valve are required for proper operation.

M/N	BTU RATING	PRES.	DIA.	LGTH	TORCH WT.
FL-10	100,000 btu/h	30 psi	2-7/8"	27"	2.0 lbs.
FL-6-S	200,000 btu/h	30 psi	3-1/2"	27"	4.0 lbs.
FL-3-S	500,000 btu/h	30 psi	4-3/4"	28"	6.0 lbs.

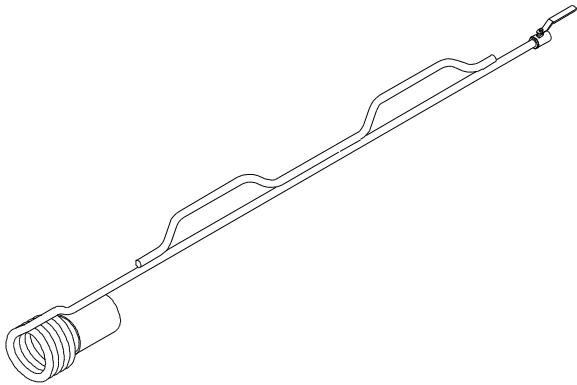

Liquid Propane Utility Torches - Long

Long style propane torches give the same great benefits as the short except the long handle gives the operator the convenience of using two hands to hold the torch, when extended periods of operation are required.

With the ability to operate on a wide variety of pressures, these torches are designed for steady operation - regardless of fuel level or ambient temperatures.

A gas pressure regulator & hydrostatic relief valve are required for proper operation.

M/N	BTU RATING	PRES.	DIA.	LGTH	TORCH WT.
FL-6-L	200,000 btu/h	30 psi	3-1/2"	57"	7.0 lbs.
FL-3-L	500,000 btu/h	30 psi	4-3/4"	60"	8.0 lbs.
FL-8	2.0 mil btu/h	30 psi	6"	62"	15.0 lbs.

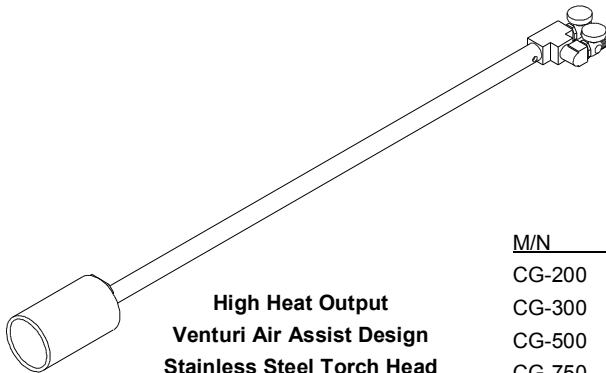

High Heat Output
Venturi Air Assist Design
Stainless Steel Torch Head
Over 2,000°F Flame Temperature

Compressed Air - Gas Utility Torch

The CG series Compressed Air & Gas Utility Torches are designed for high intensity direct heating applications. By using compressed air and a venturi mixer, the CG series torches mix either LPG or Natural Gas into a concentrated and directional flame output.

Features include, dual adjustable gas & air valves & stainless steel torch head.

REQUIRES COMPRESSED AIR SUPPLIED AT 25psi - 120 psi

M/N	BTU RATING	GAS PRES.	AIR RATE	DIA.	LGTH	TORCH WT.
CG-200	200,000 btu/h	1/2 - 30 psi	3 cfm	1-7/8"	31"	4.0 lbs.
CG-300	300,000 btu/h	1/2 - 30 psi	5 cfm	2-3/8"	33"	5.0 lbs.
CG-500	500,000 btu/h	1/2 - 30 psi	10 cfm	2-7/8"	45"	6.0 lbs.
CG-750	750,000 btu/h	1/2 - 30 psi	20 cfm	3-3/8"	59"	7.0 lbs.
CG-1000	1.0 mil btu/h	1/2 - 30 psi	25 cfm	4"	66"	9.0 lbs.
CG-1500	1.5 mil btu/h	1/2 - 30 psi	40 cfm	4-1/2"	73"	11.0 lbs.

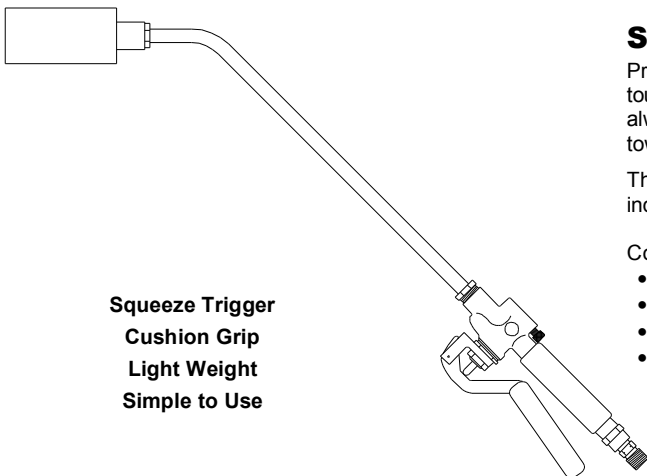

Squeeze Trigger
Cushion Grip
Light Weight
Simple to Use

Squeeze Trigger Hand Torch - Standard

Primarily designed for the roofing & paving industries, the FV-15 hand torch is built tough and easy to use. With an adjustable standing pilot flame, the FV-15 torch is always ready to go, just squeeze the trigger, and a full force flame is released towards your work area.

The FV-15 torch has been used for other applications as well, like shrink wrapping, industrial processing, floor & road drying.

Complete with:

- FV-15 Torch Assembly
- Adjustable propane gas regulator
- 25 feet of propane gas hose
- Striker, Stand & Instruction Manual

M/N	BTU RATING	PRES.	DIA.	LGTH	TORCH WT.
FV-15-K	520,000 btu/h	55 psi	2"	32"	2.4 lbs.